

APRIL 25, 2025

**RE: SOFTBALL FIELD IMPROVEMENTS
WAKONDA, SOUTH DAKOTA
SPN #16579**

BID LETTING: THURSDAY, MAY 1, 2025, 2:00 PM

ADDENDUM NUMBER 1

The following modifications are to be made to the plans and specifications for the Softball Field Improvements Project.

PLANS

The 4' Tall Chain-Link Fence Detail found on sheet 15 shall be deleted in its entirety and replaced with the attached exhibit. This addendum extends the footing depth from 2 feet to 4 feet.

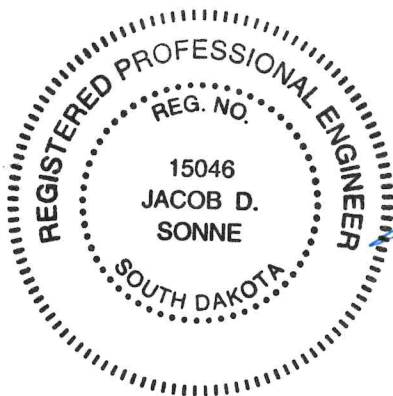

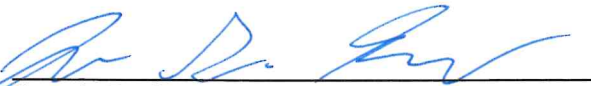

Jacob D. Sonne, Project Engineer
Schmucker, Paul, Nohr & Associates

The undersigned hereby acknowledges receipt of Addendum Number 1 to the plans and specifications for the SOFTBALL FIELD IMPROVEMENTS PROJECT.

FIRM NAME _____
BY _____
TITLE _____
DATE _____

ATTACH THIS SIGNED ADDENDUM NO. 1 TO THE BID FORM WHEN SUBMITTING.

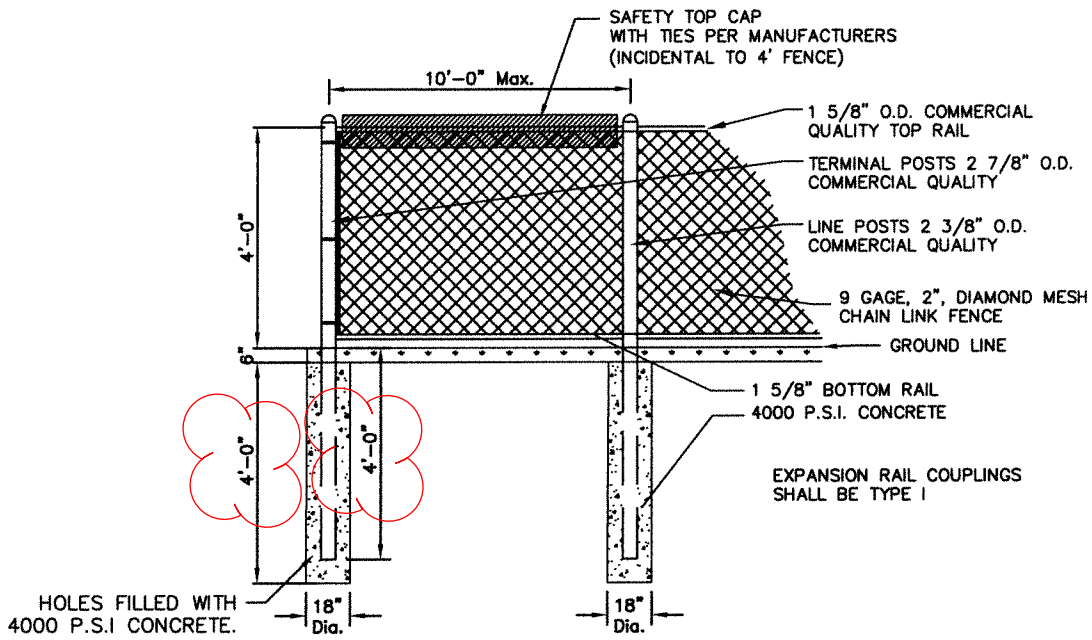

4' TALL CHAIN-LINK FENCE DETAIL

SCALE: NONE

SPN

& Associates

Engineers, Planners and Surveyors

2100 North Sanborn Blvd. - P.O. Box 398

Mitchell, South Dakota 57301

Phone: (605) 996-7761

Fax: (605) 996-0015